

< Wróć

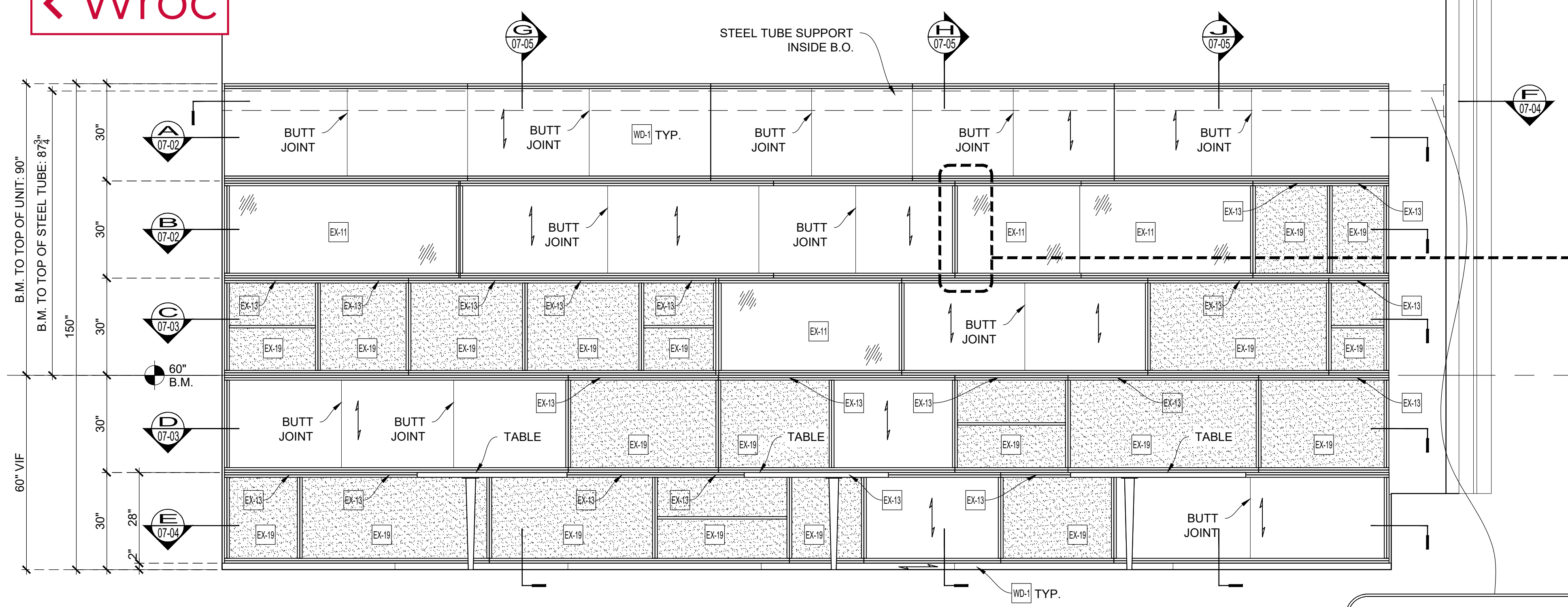

ELEVATION
SCALE: 1/2" = 1'-0"
Arch't Ref.: 1B/A-845.00

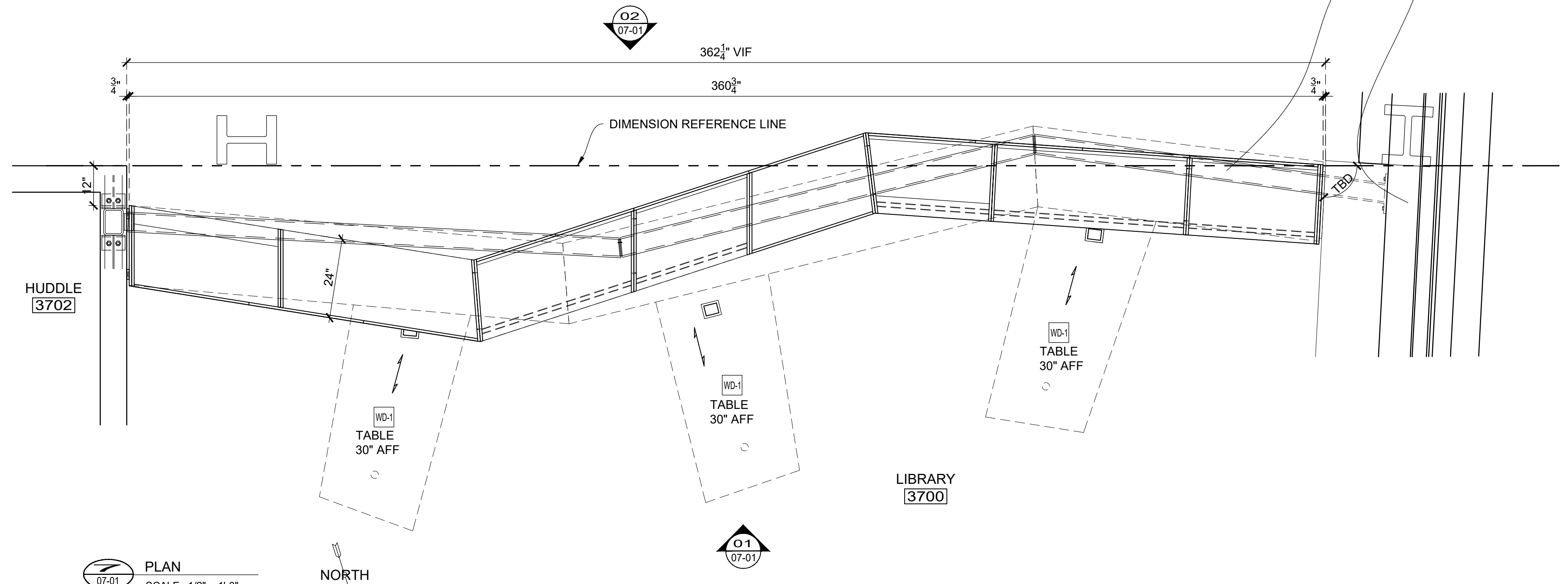

PLAN
SCALE: 1/2" = 1'-0"
Arch't Ref.: A-103.00, 1/A-846.00

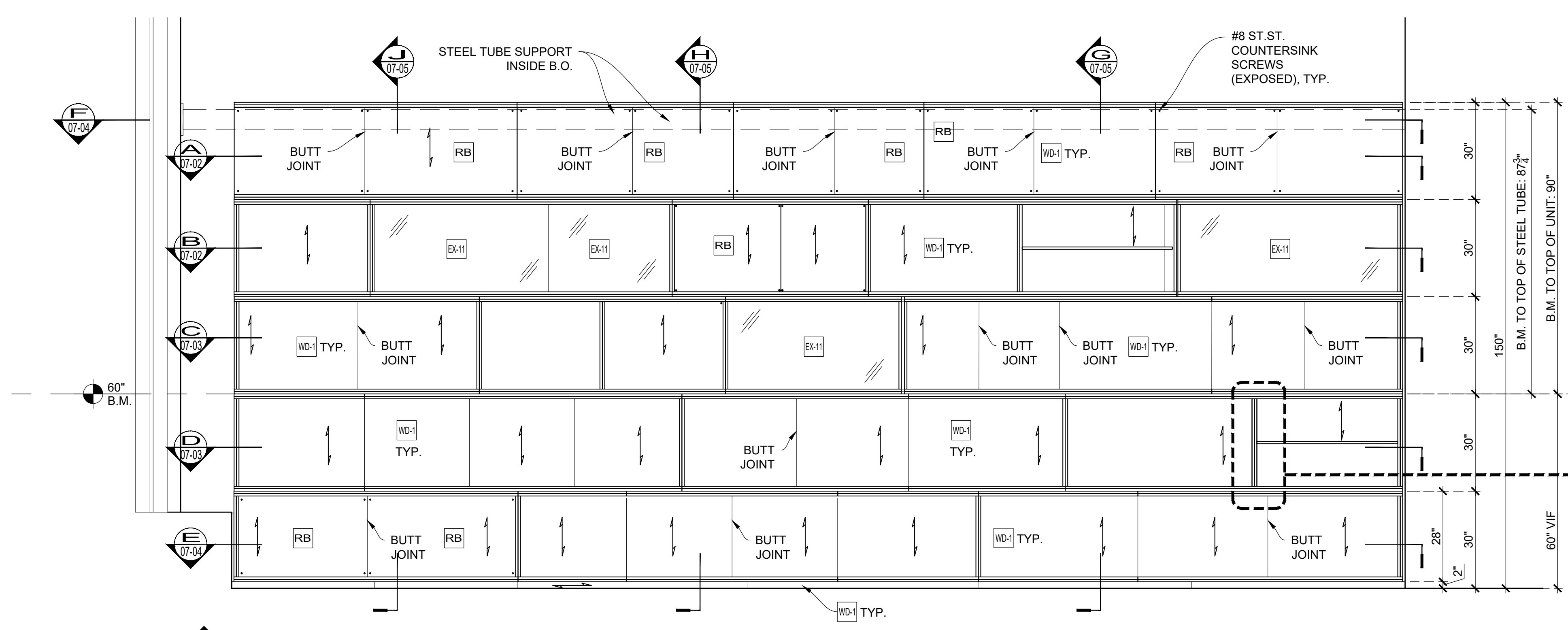

ELEVATION
SCALE: 1/2" = 1'-0"
Arch't Ref.: 1B/A-845.00

- REMOVABLE BACKS FOR FASTENING
- LOOSE TO FIELD
- INSTALLED LAST

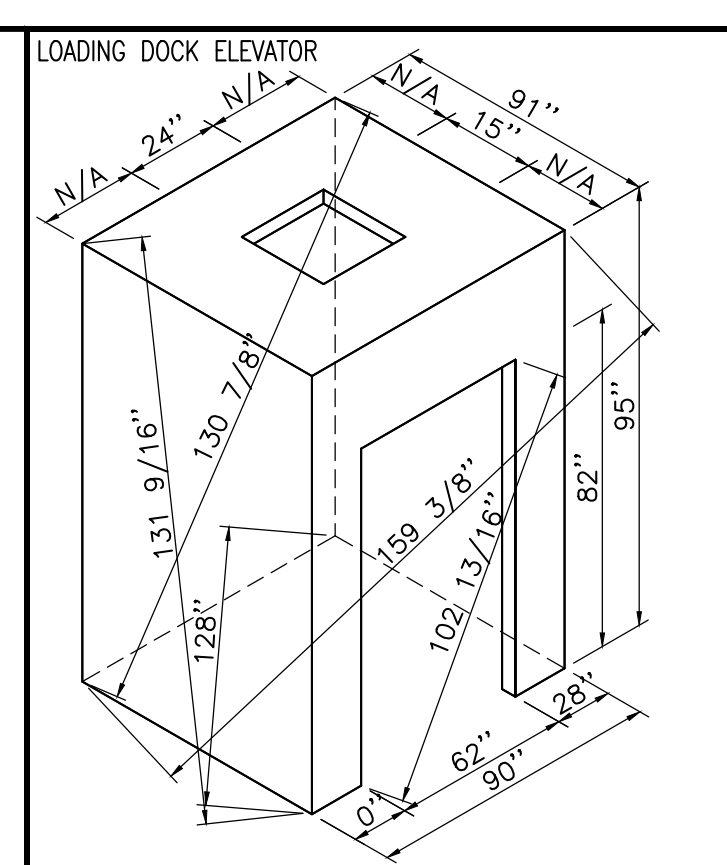
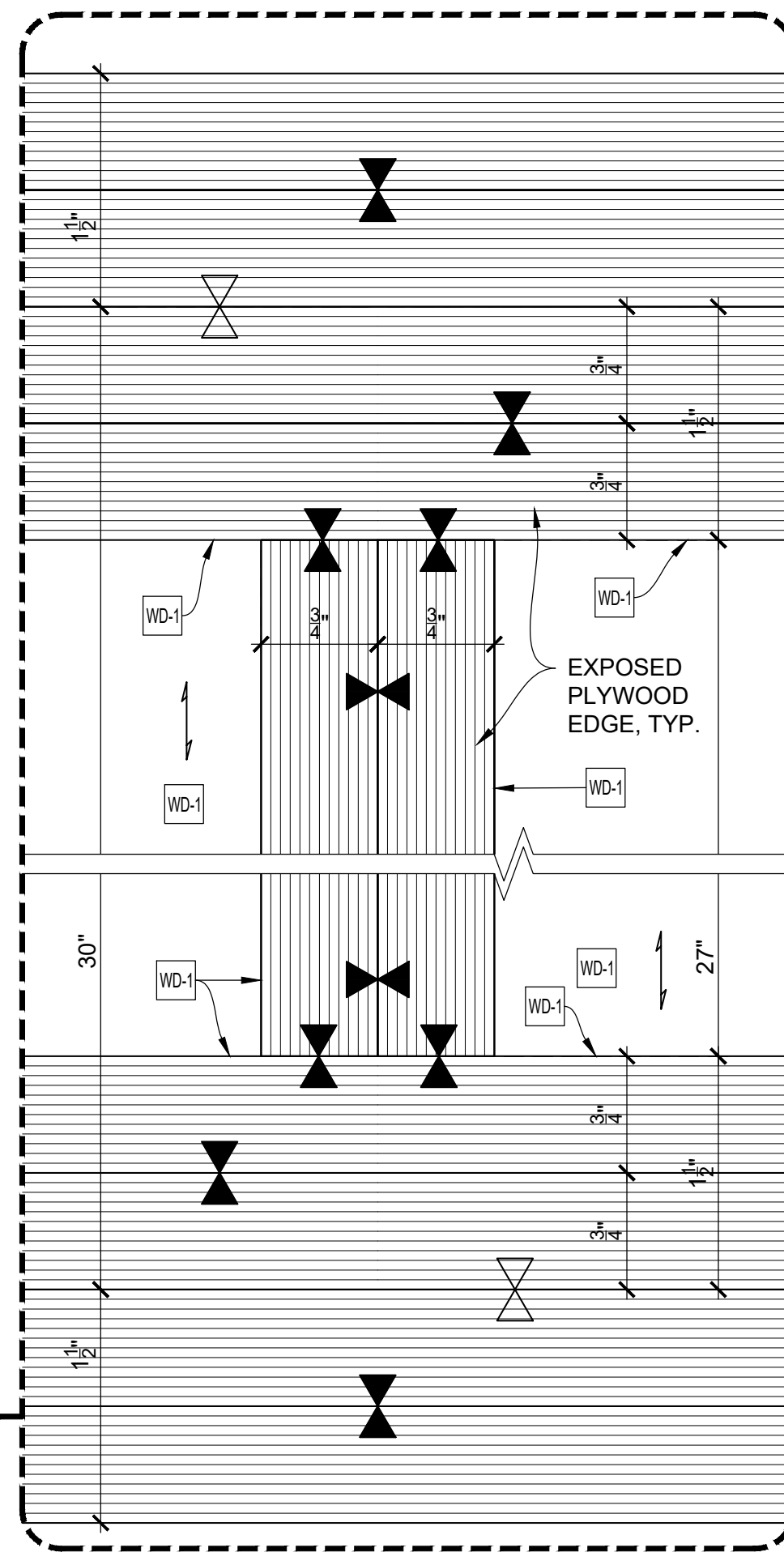
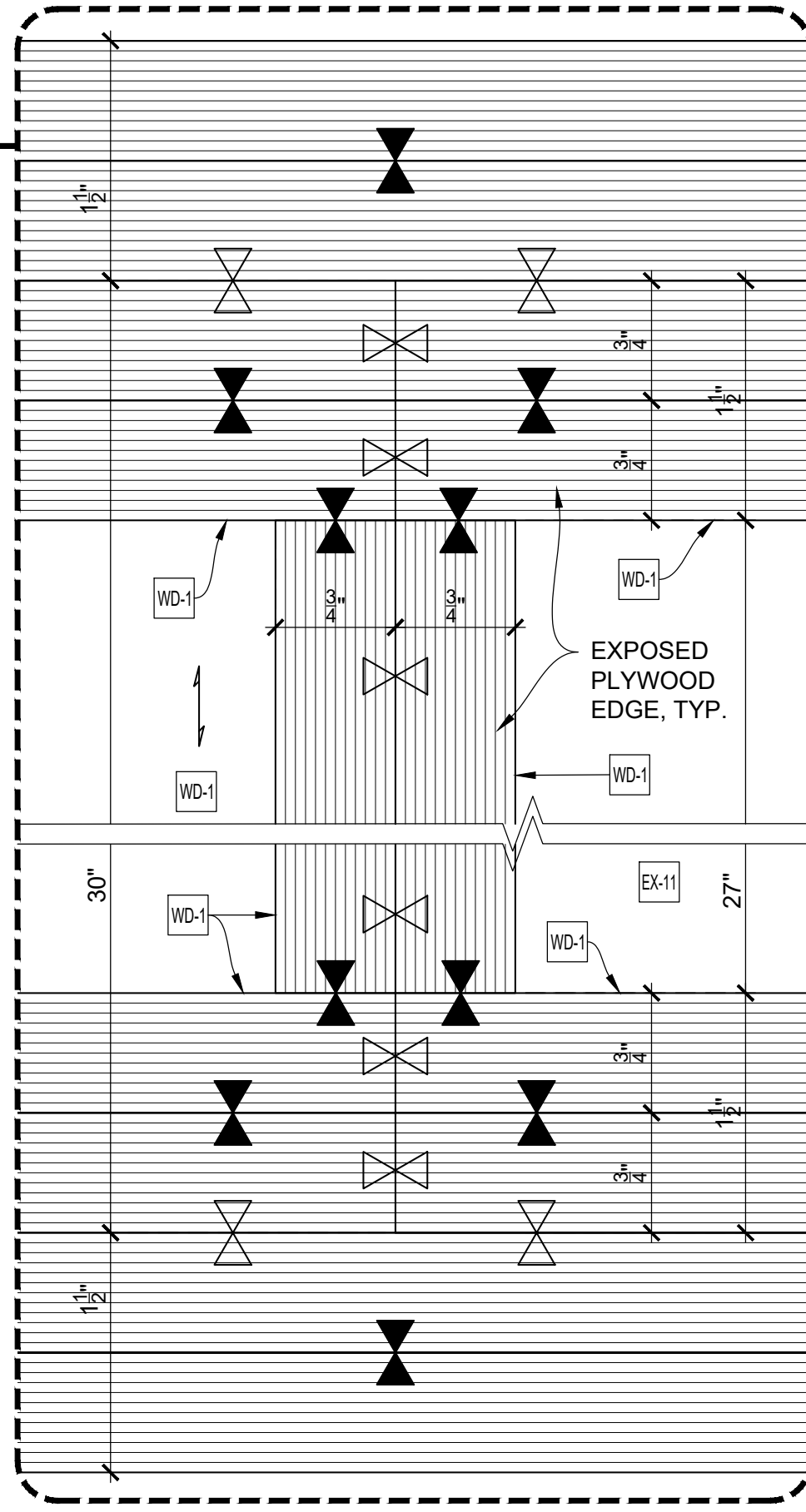

- Loose to field
- Fixed in shop

THIS SPACE RESERVED FOR FINISH SCHEDULE

THIS SPACE RESERVED FOR GENERAL NOTES

EXCLUSIONS:

- EX-11 1/2" LAMINATED GLASS
- EX-13 LIGHT FIXTURE (L15)
- EX-18 LIGHT FIXTURE (L5)
- EX-19 FABRIC PANEL 1" THK (AC1.1)

NAUF CERTIFIED PROJECT
ALL MATERIALS TO BE UREA FORMALDEHYDE FREE

DRAWING SUBMITTALS AND RETURNS				
DATE	PURPOSE	TO	RETURN	RETURN STATUS
2019-08	FOR APPROVAL	JT MAGEN	2019-02-14	APPROVED AS NOTED

DRAWING REVISIONS			
DATE	DESCRIPTION	REVISED BY	COMMENTS
1			
2			
3			
4			
5			
6			
7			
8			
9			
10			

RELEASES FOR FABRICATION	
DATE	DESCRIPTION

TITLE:	PLAN		
ITEM NO.:	PLYWOOD SHELVING UNIT AT LIBRARY 3700		
DESC.:	By:	Scale:	Job No.
	PD	As Noted	
Status: APPROVED AS NOTED	Date: 2019-01-08	Dwg. No.	07-01

TO BE COORDINATED WITH
STRUCTURAL STEEL DRAWINGS

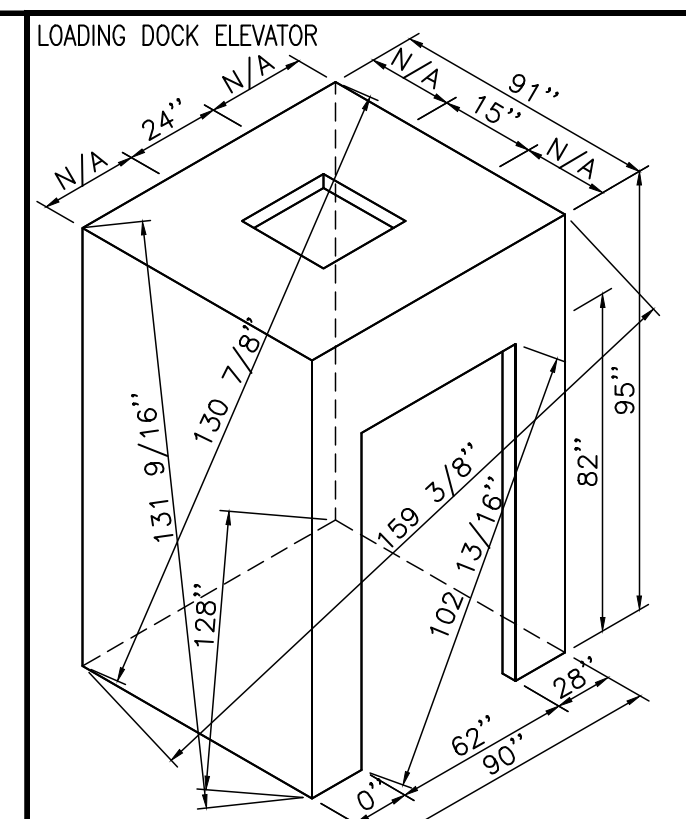

⊗ Loose to field
⊠ Fixed in shop

THIS SPACE
RESERVE
FOR FINISH
SCHEDULE

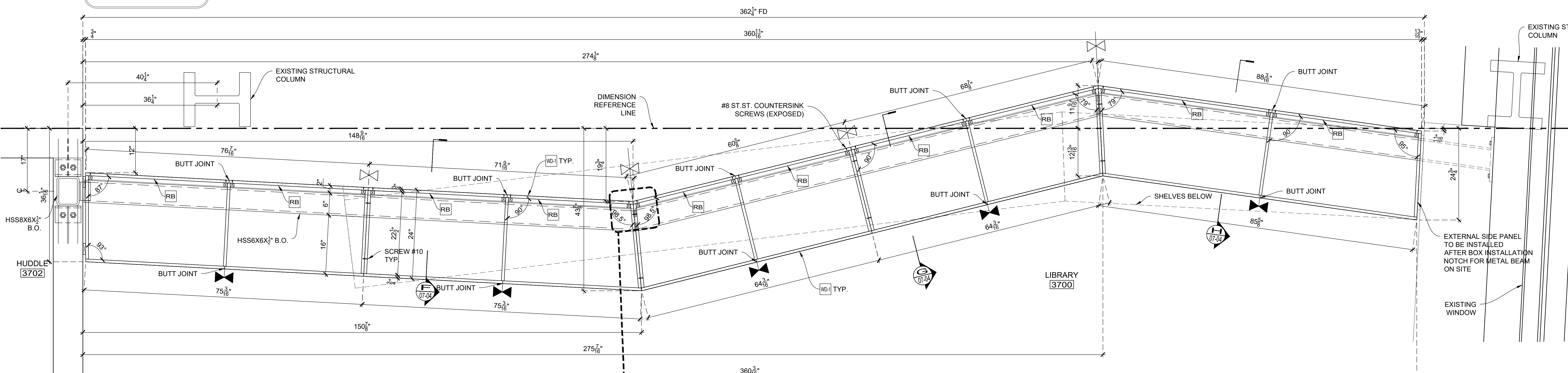

PLAN SECTION
SCALE: 1" = 1'-0"
Arch't Ref.: 1E/A-846.00

RB - REMOVABLE BACKS FOR FASTENING
- LOOSE TO FIELD
- INSTALLED LAST

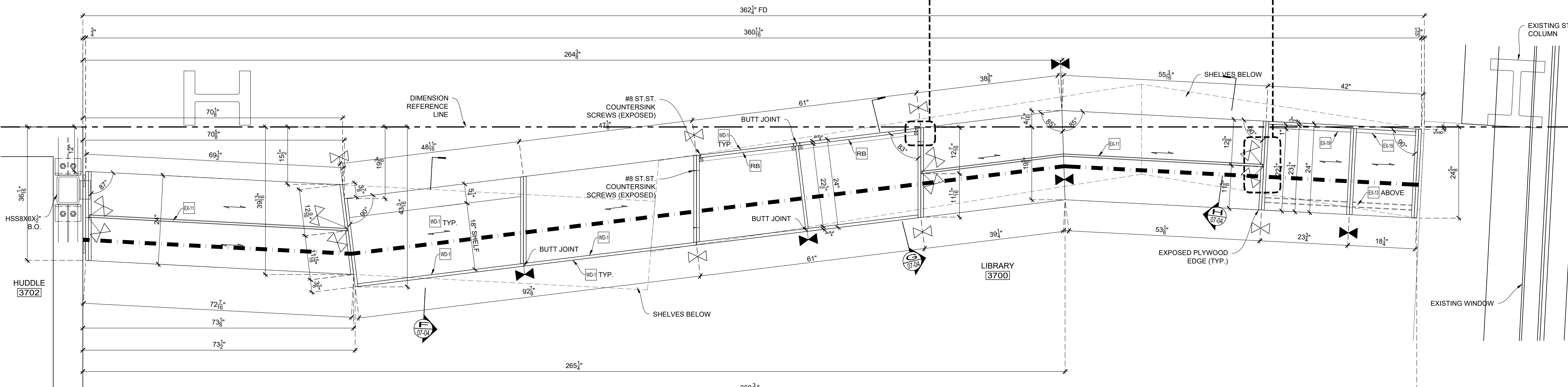
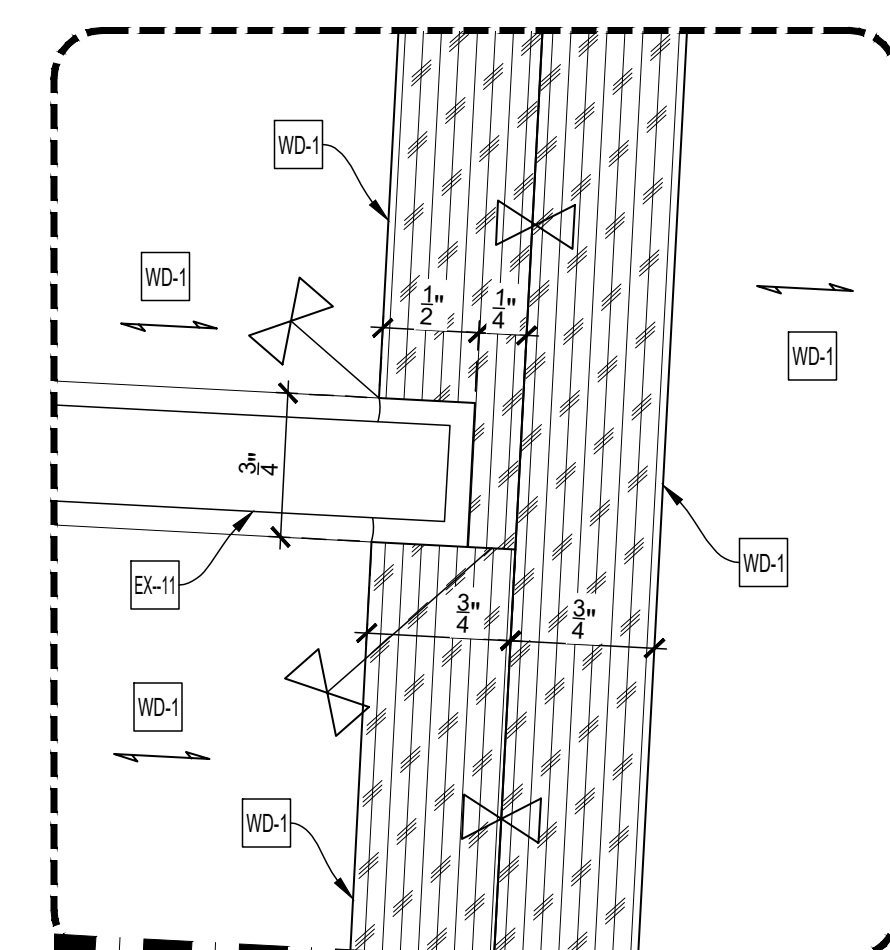
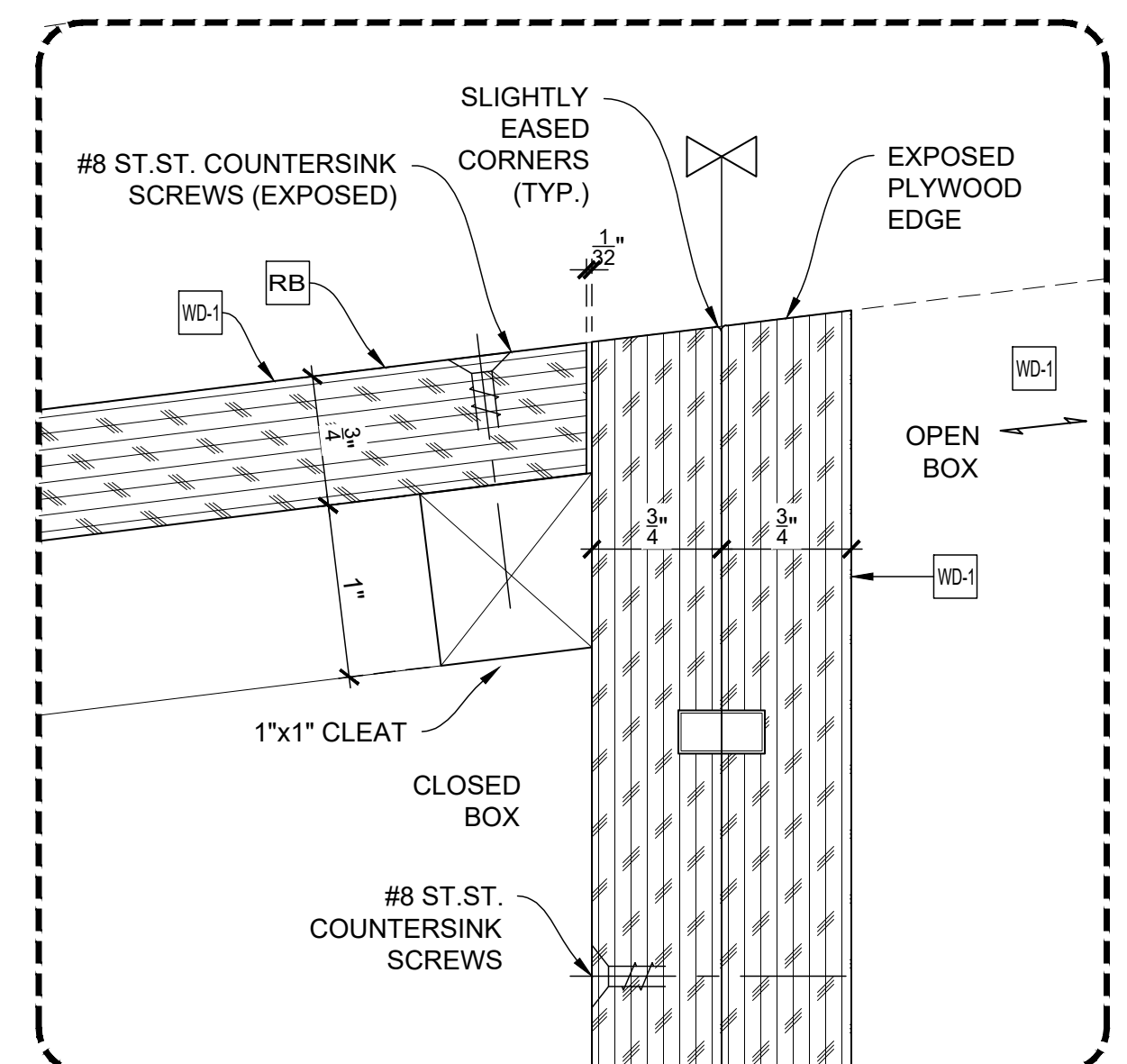
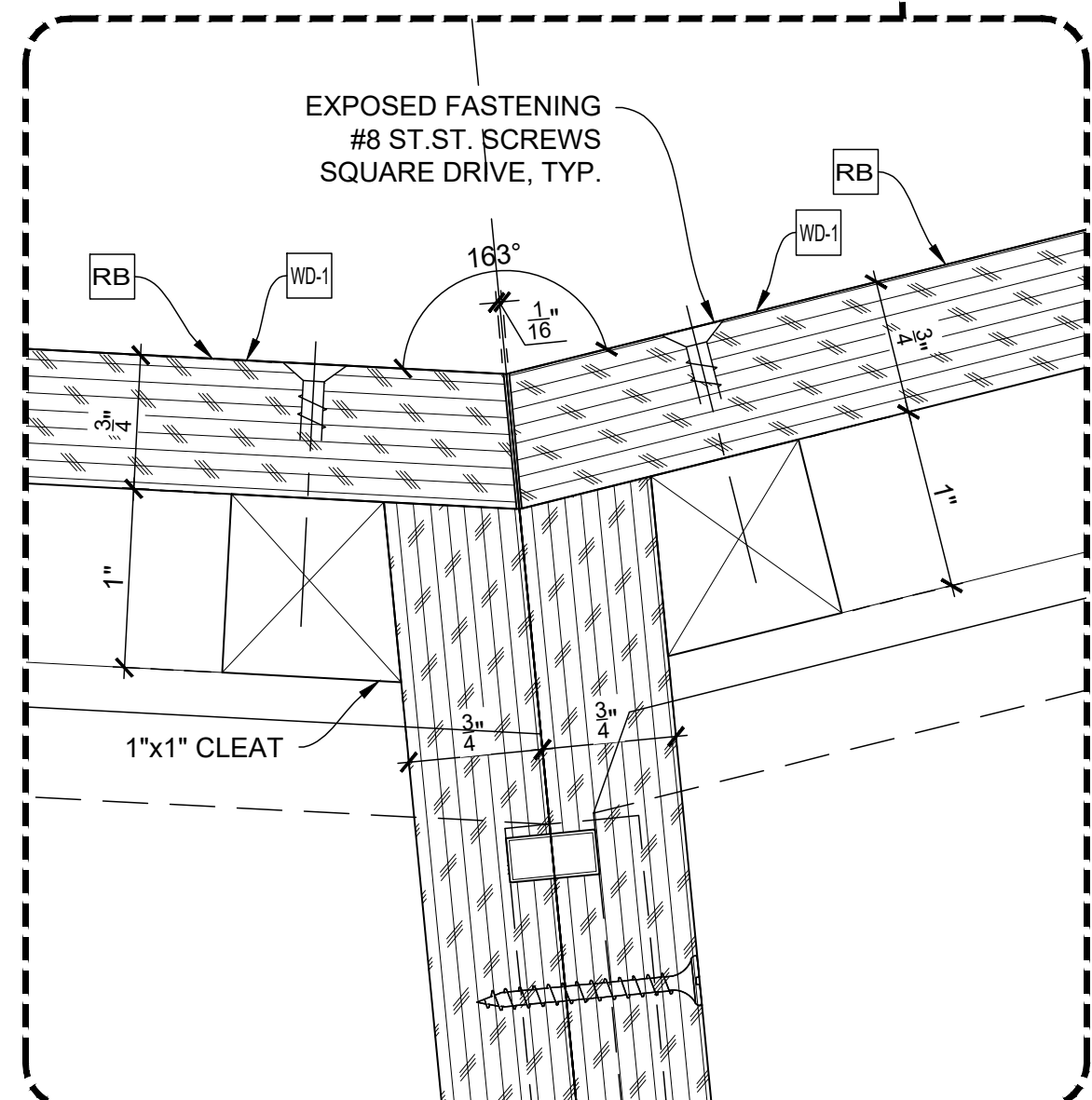

PLAN SECTION
SCALE: 1" = 1'-0"
Arch't Ref.: 1E/A-846.00

--- 2" x 3" ROUTED GROOVE CONTINUOUS AT TOP OF EACH LEVEL FOR LOW VOLTAGE WIRES TO FIXTURE L15

- EXCLUSIONS:
- EX-11 12" LAMINATED GLASS
 - EX-13 LIGHT FIXTURE (L15)
 - EX-18 LIGHT FIXTURE (L5)
 - EX-19 FABRIC PANEL 1" THK. (AC1.1)

NAUF CERTIFIED PROJECT
ALL MATERIALS TO BE UREA FORMALDEHYDE FREE

DRAWING SUBMITTALS AND RETURNS				
DATE	PURPOSE	TO	RETURN	RETURN STATUS
2018-01	FOR APPROVAL	JT MAGEN	2018-02-14	APPROVED AS NOTED

DRAWING REVISIONS				
DATE	DESCRIPTION	REVISED BY	COMMENTS	
1				
2				
3				
4				
5				
6				
7				
8				
9				
10				

RELEASES FOR FABRICATION	
DATE	DESCRIPTION

← Wróć

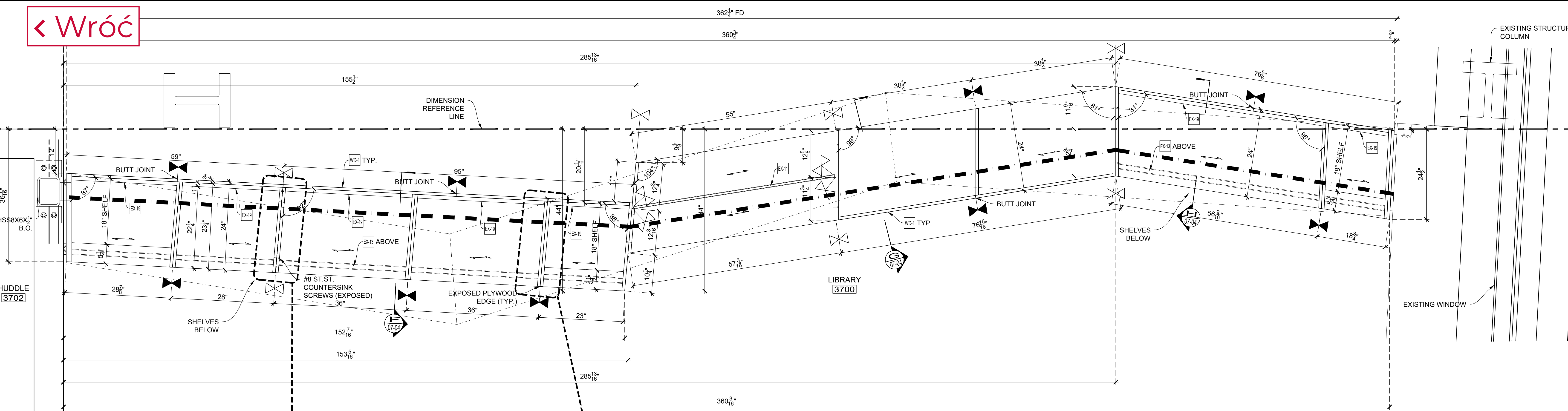

C PLAN SECTION
SCALE: 1" = 1'-0"
Arch Ref.: 1D/A-846.00

ARCHITECT NOTE:
PLEASE VERIFY ALL LOCATIONS OF LIGHT FIXTURE (EX-13)

- REMOVABLE BACKS FOR FASTENING
- LOOSE TO FIELD
- INSTALLED LAST

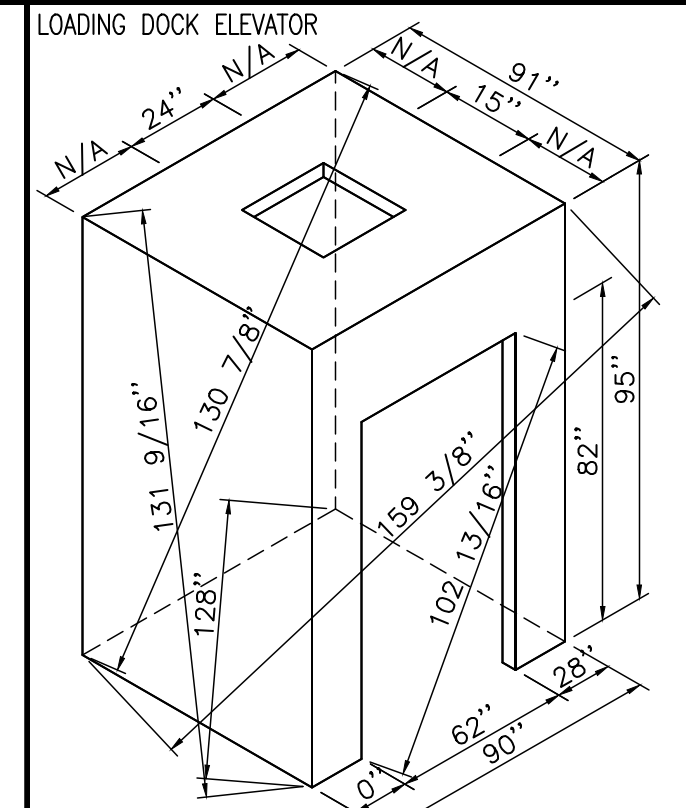
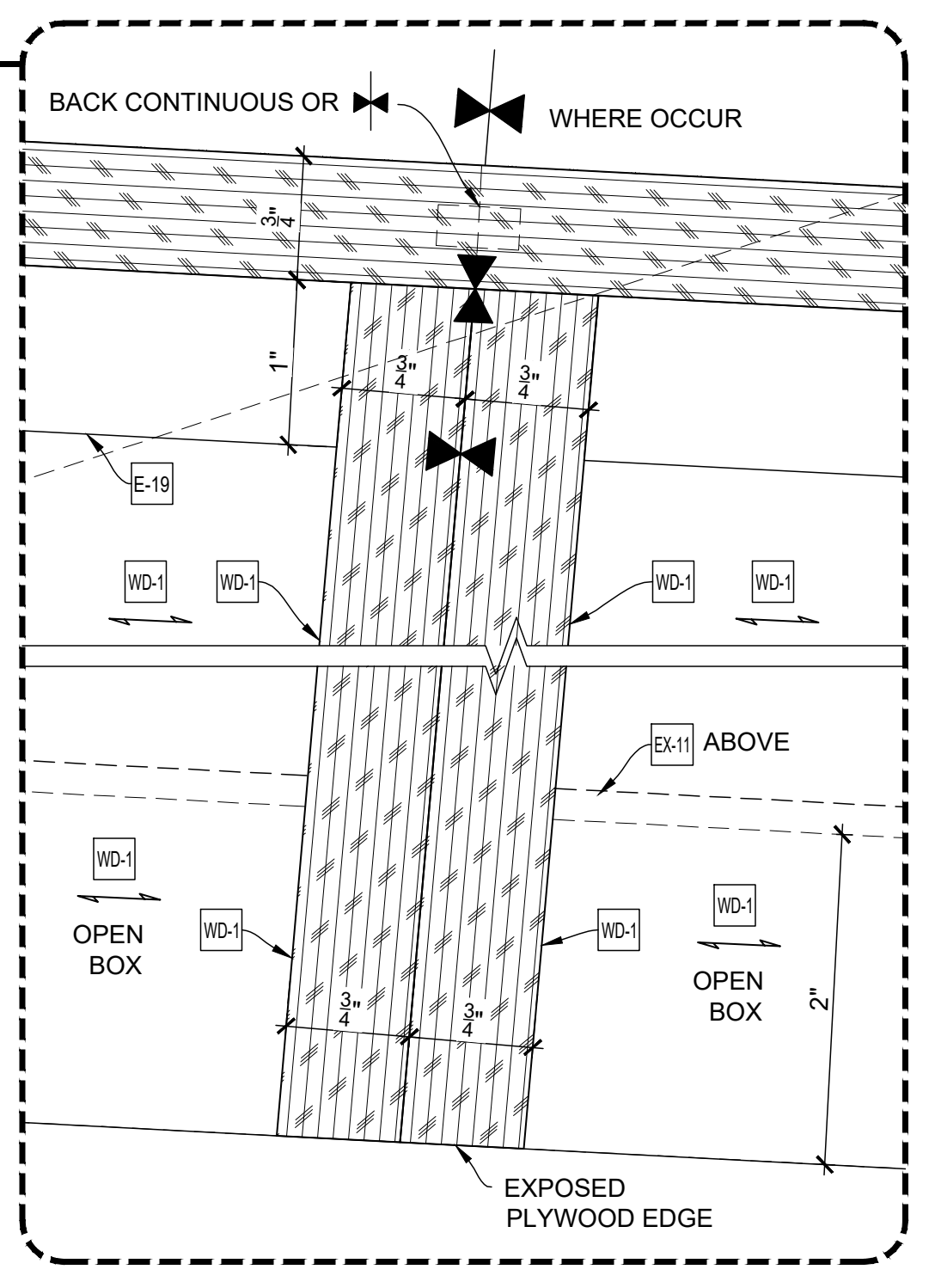
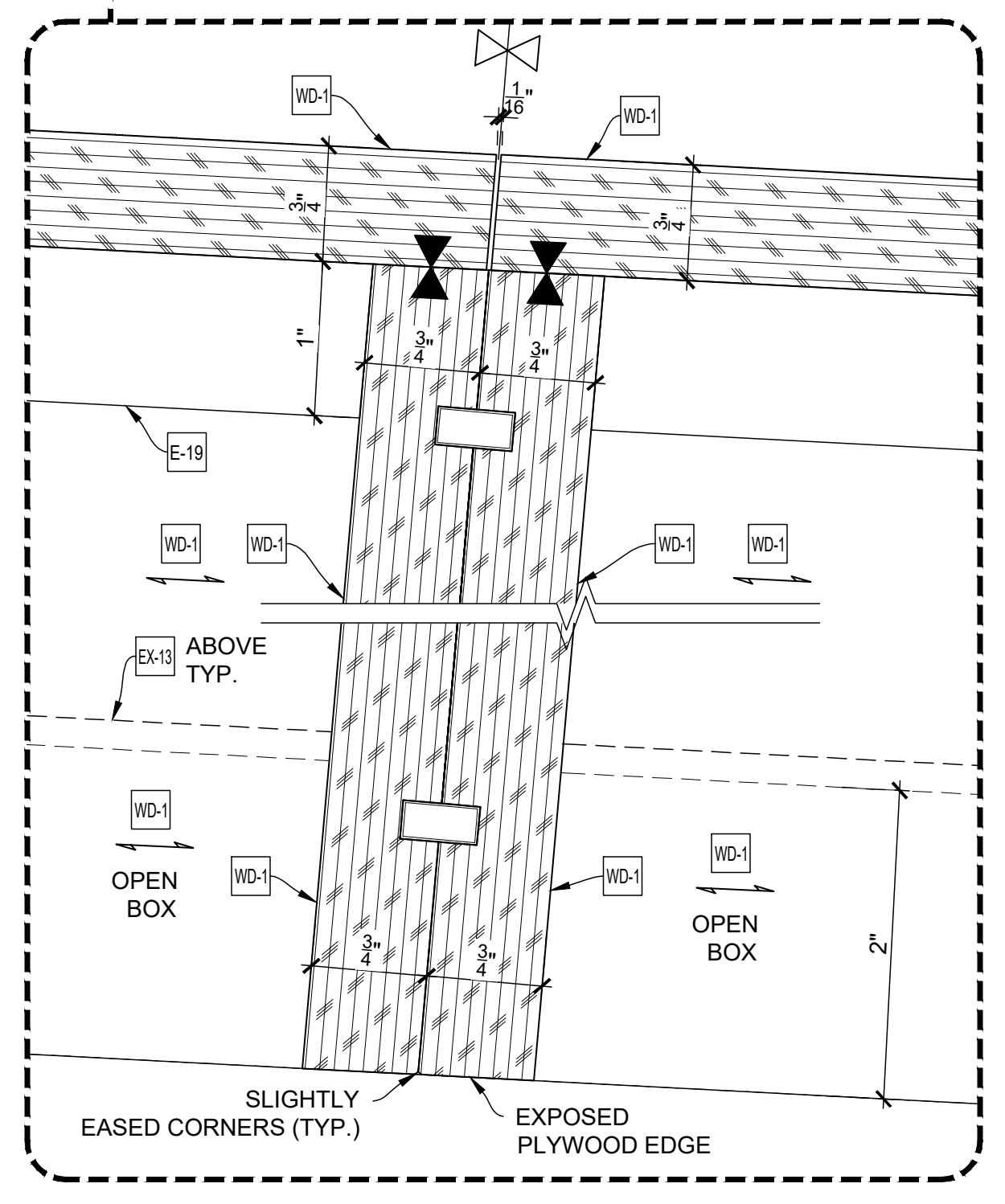

- ⊗ Loose to field
- ⊠ Fixed in shop

THIS SPACE IS RESERVED FOR FINISH SCHEDULE

- EXCLUSIONS:**
- EX-11 1/2" LAMINATED GLASS
 - EX-13 LIGHT FIXTURE (L15)
 - EX-18 LIGHT FIXTURE (L5)
 - EX-19 FABRIC PANEL 1" THK. (AC1.1)

NAUF CERTIFIED PROJECT
ALL MATERIALS TO BE UREA FORMALDEHYDE FREE

DRAWING SUBMITTALS AND RETURNS				
DATE	PURPOSE	TO	RETURN	RETURN STATUS
2019-09	FOR APPROVAL	JT MAGEN	2019-02-14	APPROVED AS NOTED

DRAWING REVISIONS				
DATE	DESCRIPTION	REVISED BY	REVISION	COMMENTS
1				
2				
3				
4				
5				
6				
7				
8				
9				
10				

RELEASES FOR FABRICATION	
DATE	DESCRIPTION

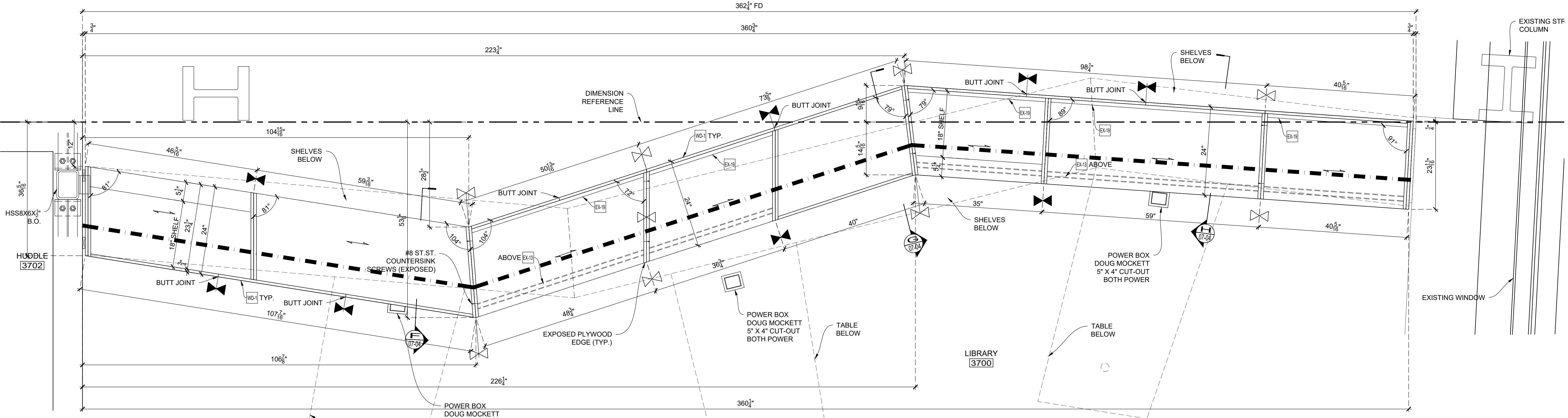

D PLAN SECTION
SCALE: 1" = 1'-0"
Arch Ref.: 1C/A-846.00

TITLE: Library Shelving Unit And Tables			
ITEM NO:	7		
DESC:	SECTIONS		
DESC:	PLYWOOD SHELVING UNIT AT LIBRARY 3700		
By:	PD	Scale: As Noted	Job No.
Status: APPROVED AS NOTED	Date: 2019-01-08	Dwg. No.	07-03

< Wróć

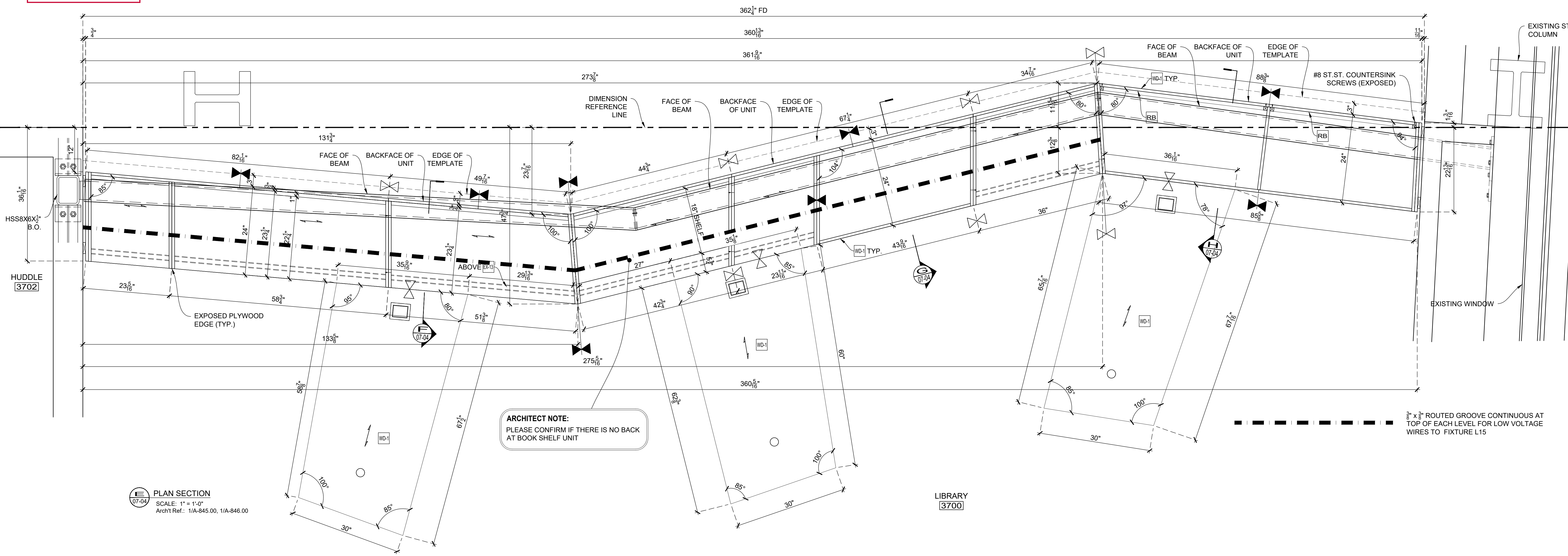

PLAN SECTION
SCALE: 1" = 1'-0"
Arch't Ref.: 1/A-845.00, 1/A-846.00

ARCHITECT NOTE:
PLEASE CONFIRM IF THERE IS NO BACK AT BOOK SHELF UNIT

LIBRARY
3700

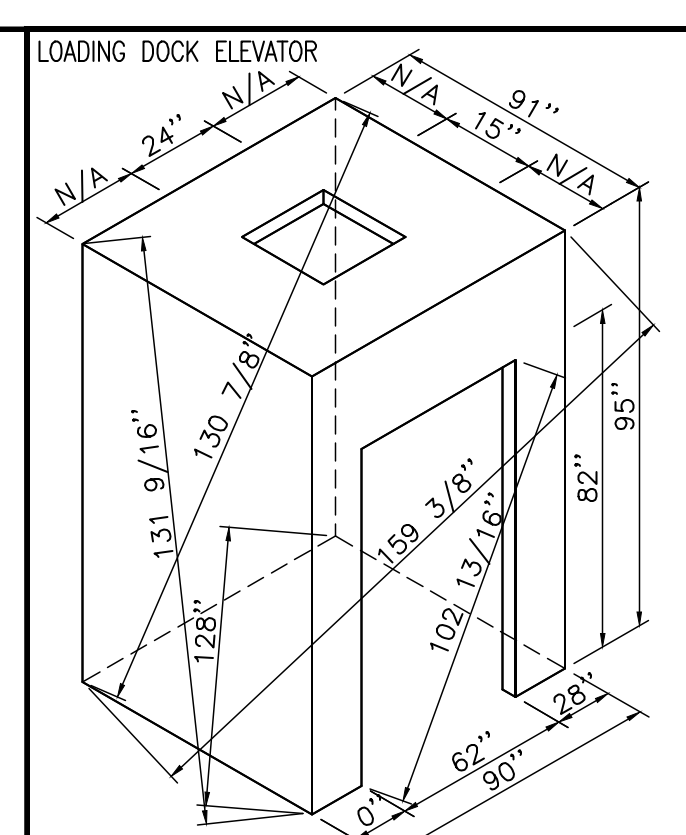

Loose to field
Fixed in shop

THIS SPACE RESERVE FOR FINISH SCHEDULE

1/2" x 3/8" ROUTED GROOVE CONTINUOUS AT TOP OF EACH LEVEL FOR LOW VOLTAGE WIRES TO FIXTURE L15

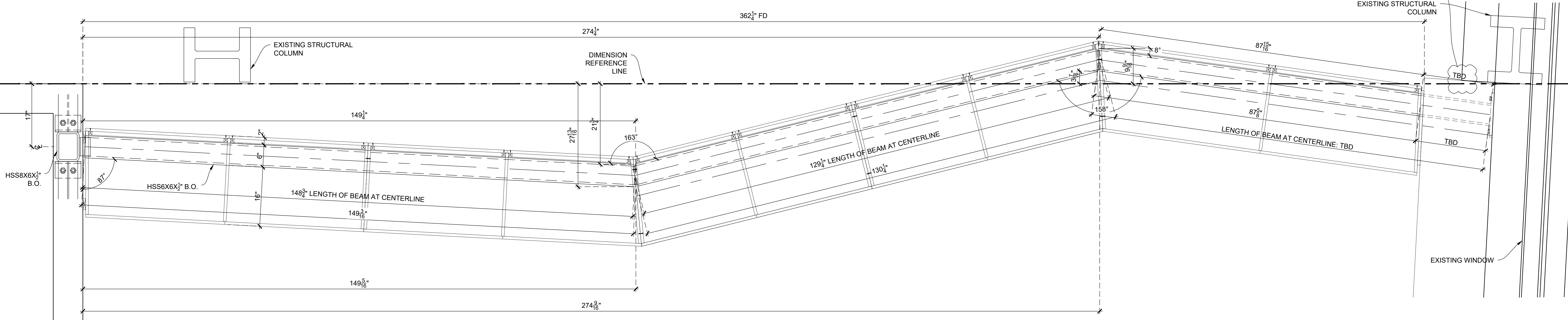

PLAN SECTION
SCALE: 1" = 1'-0"
Arch't Ref.: NONE

SEPARATE PLAN SECTION OF UPPER LEVEL FOR COORDINATION OF THE STEEL STRUCTURE

TO BE COORDINATED BY STEEL INSTALLER/VENDOR

EXISTING STRUCTURAL COLUMN

EXISTING WINDOW

- REMOVABLE BACKS FOR FASTENING
- LOOSE TO FIELD
- INSTALLED LAST

EXCLUSIONS:

EX-11	12" LAMINATED GLASS
EX-13	LIGHT FIXTURE (L15)
EX-18	LIGHT FIXTURE (L5)
EX-19	FABRIC PANEL 1" THK. (AC1.1)

NAUF CERTIFIED PROJECT
ALL MATERIALS TO BE UREA FORMALDEHYDE FREE

DRAWING SUBMITTALS AND RETURNS

DATE	PURPOSE	TO	RETURN	RETURN STATUS
2019-09	FOR APPROVAL	JT MAGEN	2019-02-14	APPROVED AS NOTED

DRAWING REVISIONS

DATE	DESCRIPTION	REVISED BY	COMMENTS
1			
2			
3			
4			
5			
6			
7			
8			
9			
10			

RELEASES FOR FABRICATION

DATE	DESCRIPTION

TITLE: Library Shelving Unit And Tables
ITEM NO: 7
DESC.: SECTIONS
PLYWOOD SHELVING UNIT AT LIBRARY 3700
By: PD Scale: As Noted Job No. Dwg. No.
Status: APPROVED AS NOTED Date: 2019-01-08 **07-04**

← Wrót

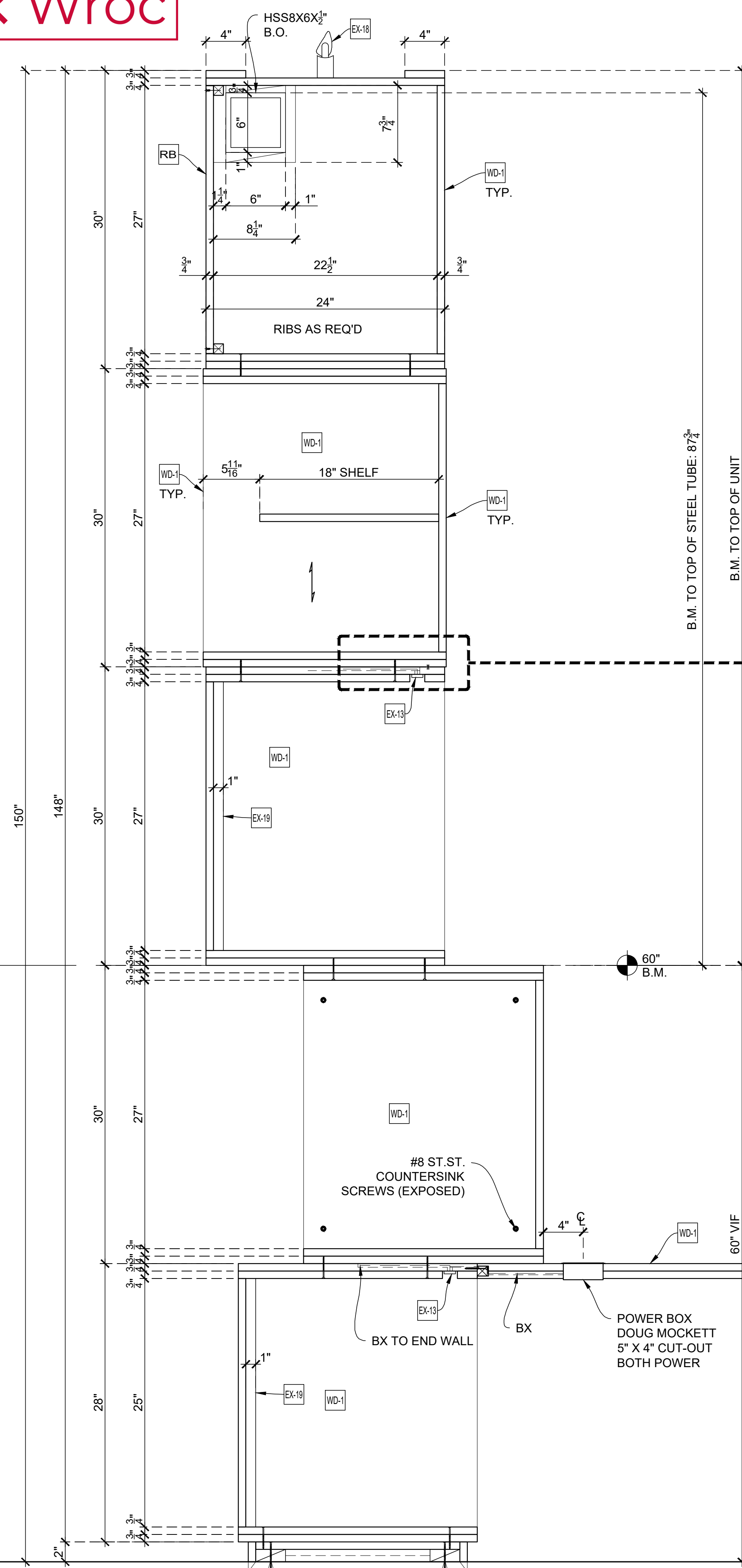

VERTICAL SECTION
SCALE: 1-1/2" = 1'-0"
Arch't Ref.: 1C/A-845.00, 1B/A-846.00

- REMOVABLE BACKS FOR FASTENING
- LOOSE TO FIELD
- INSTALLED LAST

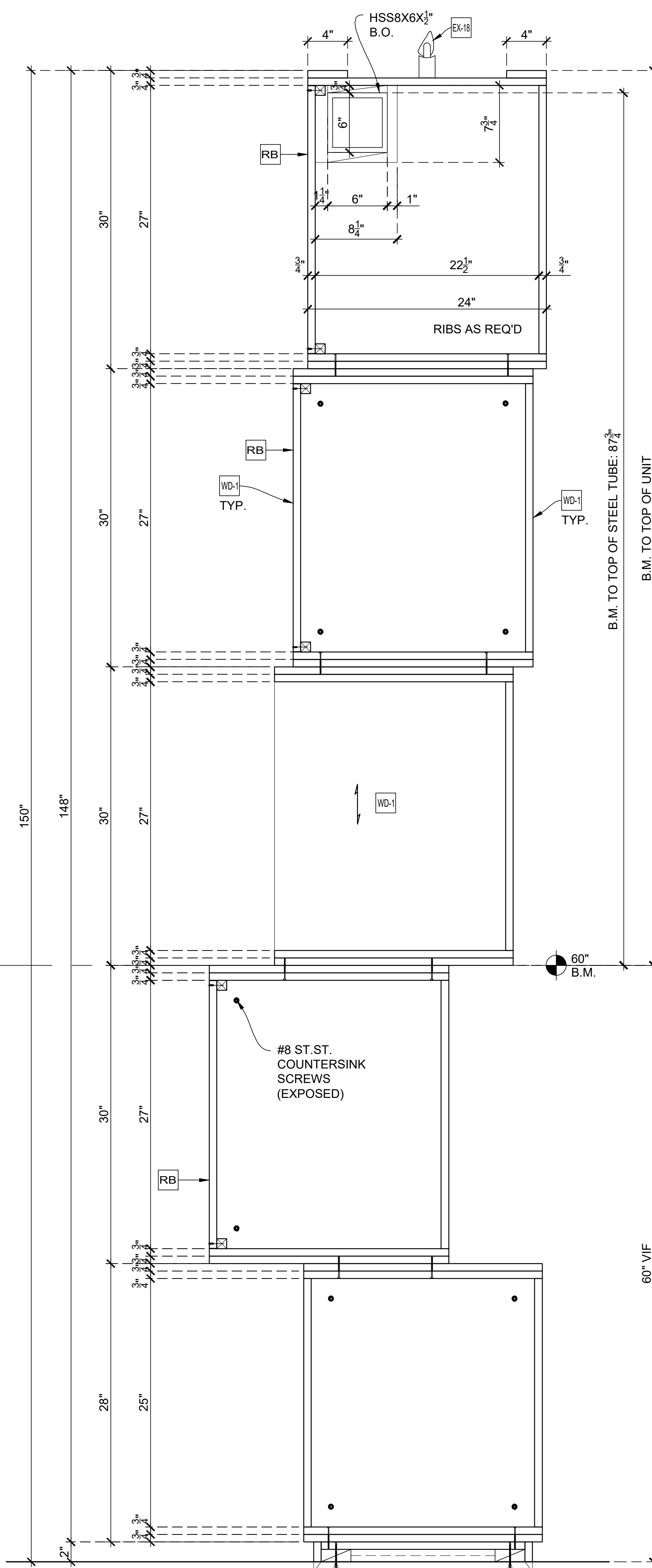

VERTICAL SECTION
SCALE: 1-1/2" = 1'-0"
Arch't Ref.: 1C/A-845.00

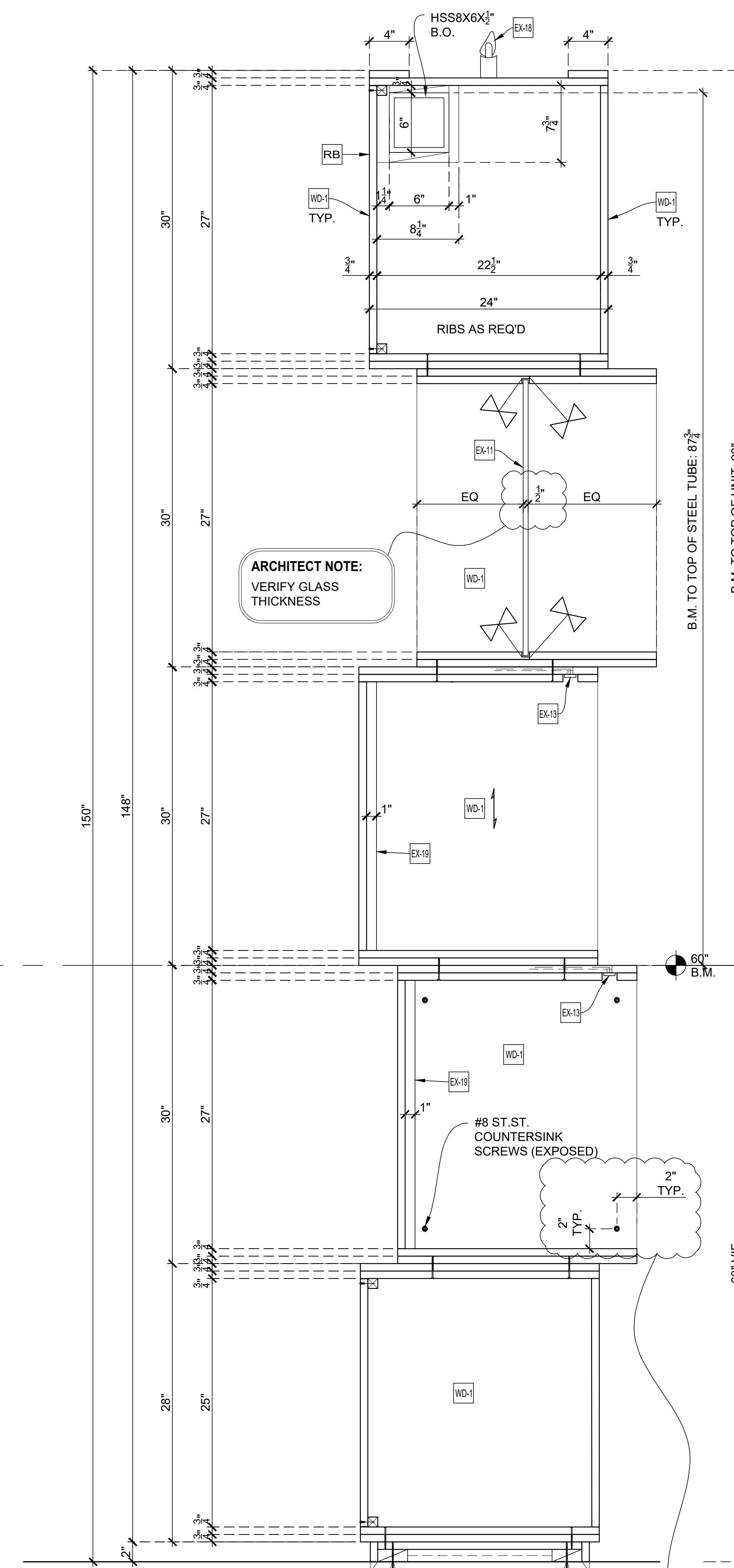

VERTICAL SECTION
SCALE: 1-1/2" = 1'-0"
Arch't Ref.: 1C/A-845.00

HOLD DIMENSION IF POSSIBLE

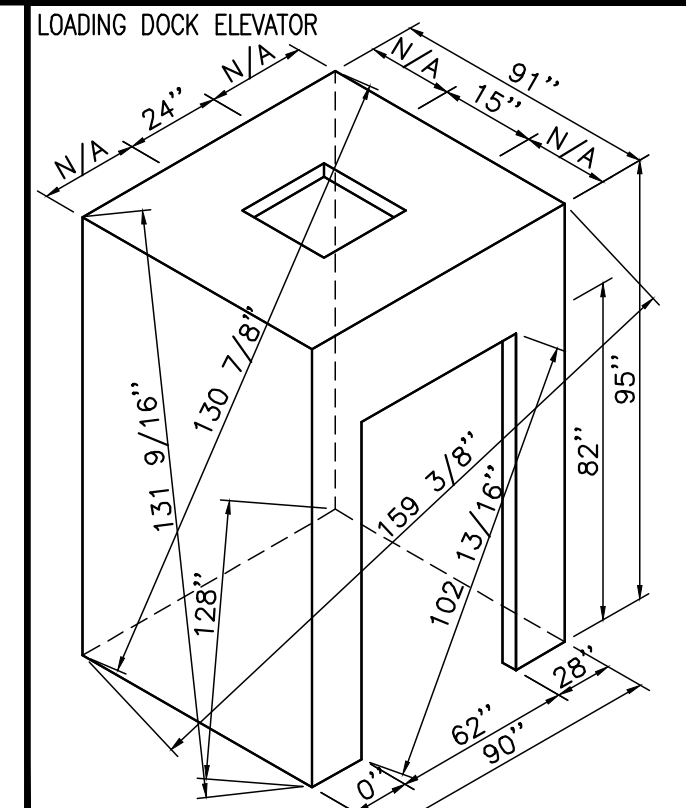
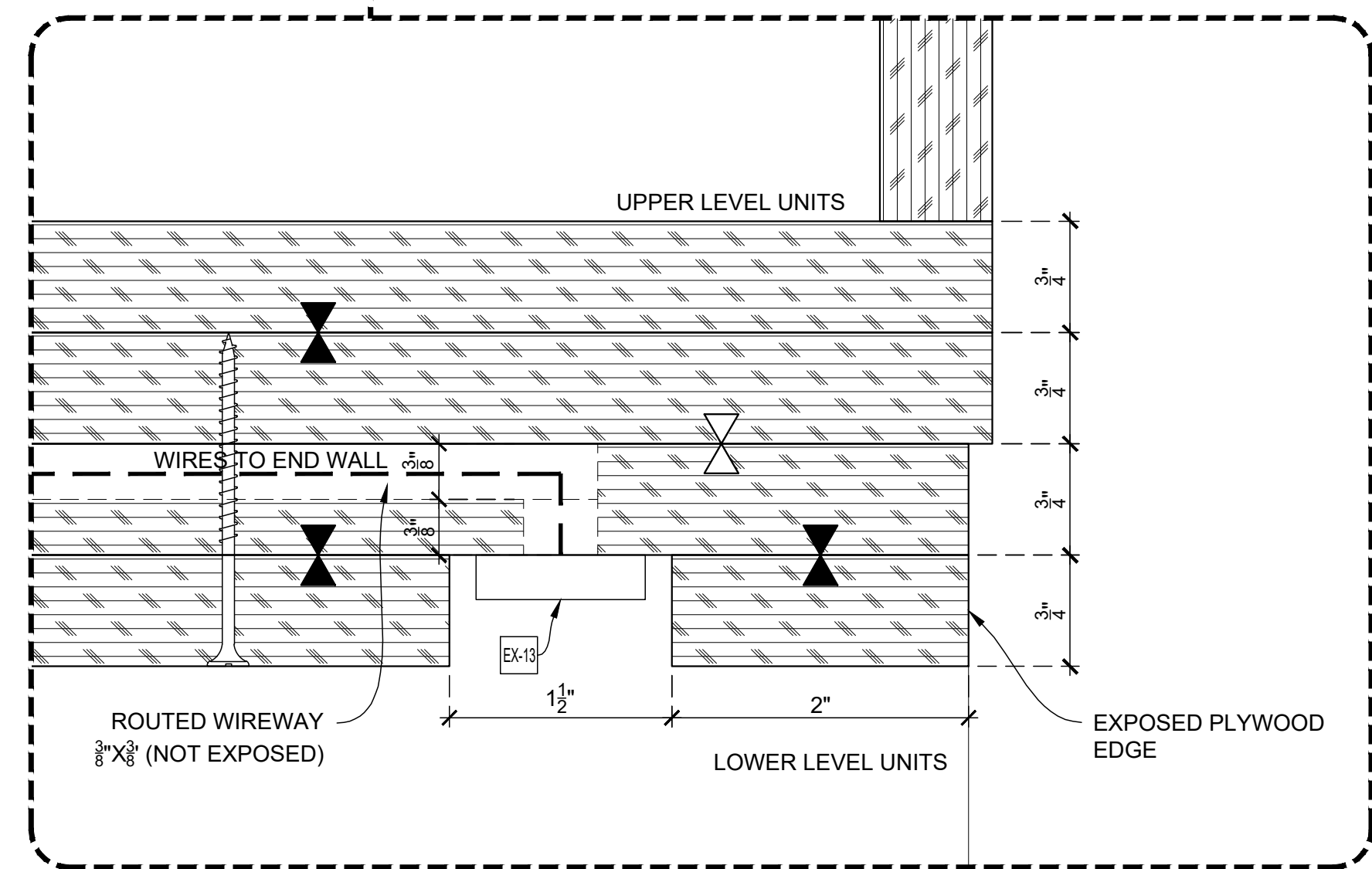

- Loose to field
- Fixed in shop

THIS SPACE RESERVE FOR FINISH SCHEDULE

EXCLUSIONS:

EX-11	1/2" LAMINATED GLASS
EX-13	LIGHT FIXTURE (L15)
EX-18	LIGHT FIXTURE (L5)
EX-19	FABRIC PANEL 1" THK. (AC1.1)

NAUF CERTIFIED PROJECT
ALL MATERIALS TO BE UREA FORMALDEHYDE FREE

DATE	PURPOSE	TO	RETURN	RETURN STATUS
2019-01	FOR APPROVAL	JT MAGEN	2019-02-14	APPROVED AS NOTED

DATE	DESCRIPTION	REVISED BY	COMMENTS

DATE	DESCRIPTION



DRAWING CHECKLIST

	BY	DATE	CHECKLIST FOR ORIGINAL DRAFTING	COMMENTS
✓	PD	2019-01-08	ARCHITECTURAL ELEVATIONS CHECKED AGAINST RCP FOR CEILING HEIGHTS AND SOFFITS	NO FOLLOW UP NEEDED
✓	PD	2019-01-08	DRAWINGS CHECKED FOR INCLUSION OF ALL ITEMS IN SCOPE	NO FOLLOW UP NEEDED
✓	NA	NA	NOTIFIED ENGINEERING MANAGER OF DISCREPANCIES BETWEEN SCOPE AND ARCHITECTURALS	NOT APPLICABLE
✓	PD	2019-01-08	MATERIALS CHECKED AGAINST SCOPE TO VERIFY WHETHER PROVIDED BY MB	NO FOLLOW UP NEEDED
✓	PD	2019-01-08	ALL FINISHES ACCURATELY LISTED AND ASSIGNED TO DRAWING	NO FOLLOW UP NEEDED
✓	PD	2019-01-08	ALL VISIBLE MILLWORK ELEVATED INCLUDING FINISHED END PANELS AND SOFFITS	NO FOLLOW UP NEEDED
✓	PD	2019-01-08	ALL MARKERS AND TAGS CHECKED AND VERIFIED TO BE CORRECT	NO FOLLOW UP NEEDED
✓	PD	2019-01-08	CASEWORK DRAWN PER MB STANDARDS WHEREVER POSSIBLE	NO FOLLOW UP NEEDED
✓	NA	NA	APPLIANCES CHECKED AGAINST CUTS AND CUSTOM PANEL DRAWINGS CREATED AS NEEDED	NOT APPLICABLE
✓	NA	NA	DOOR HARDWARE SHOWN TO THE EXTENT POSSIBLE PER HARDWARE SCHEDULE AND CUTS	NOT APPLICABLE
✓	NA	NA	HARDWARE LOCATIONS DIMENSIONED OR REQUESTED FROM ENGINEERING MANAGER	NOT APPLICABLE
✓	PD	2019-01-08	TITLE BLOCK FILLED OUT COMPLETELY AND ACCURATELY - IE SHEET NUMBERS AND DESCRIPTIONS	NO FOLLOW UP NEEDED
✓	PD	2019-01-08	ALL CABINET HARDWARE ACCURATELY LISTED INCLUDING FINISHES	NO FOLLOW UP NEEDED
✓	PD	2019-01-08	ALL SPELLING CHECKED AND VERIFIED TO BE CORRECT	NO FOLLOW UP NEEDED
✓	NA	NA	MODEL SPACE LEFT CLEAN OF UN-NEEDED GEOMETRY	NOT APPLICABLE
✓	NA	NA	NOTES REGARDING WATERPROOF CORES INCLUDED WHERE APPLICABLE	NOT APPLICABLE
✓	PD	2019-01-08	ELEVATIONS DRAWN WITH REFERENCES TO BENCHMARK	NO FOLLOW UP NEEDED
✓	NA	NA	ALL ROUGH OPENINGS CLEARLY DIMENSIONED AND REFERENCED TO BENCHMARK	NOT APPLICABLE
✓	NA	NA	ALL DOORS BY MB TAGGED CORRECTLY IN MODELSPACE	NOT APPLICABLE
✓	NA	NA	ALL DOOR SWINGS VERIFIED TO BE SHOWN AND SCHEDULED CORRECTLY	NOT APPLICABLE

USE ATTRIBUTE EDIT COMMAND ON AN ITEM TO EDIT USERNAME, DATE, AND COMMENTS

✓	PD	2019-01-08	CHECKLIST ITEM	NO FOLLOW UP NEEDED
⚠	PD	2019-01-08	CHECKLIST ITEM	NEEDS FOLLOW UP
✓	NA	NA	CHECKLIST ITEM	NOT APPLICABLE

Z:\CS\BY\PROGRAM\MB\2019\1\18\19_01_18_08_770\BSC\DWG\SUBMISSIONS\19_01_18_08_770_CLEANING_SCHEDULE.dwg



REVISION CHECKLIST

BY	DATE	CHECKLIST FOR DRAWING REVISIONS	COMMENTS
		ALL REDLINE REVISIONS MADE AND HIGHLIGHTED ON PRINTED COPY	
		ALL IMPLICATIONS OF REDLINE MARKUPS CONSIDERED AND CORRECTED	
		ENGINEERING MANAGER NOTIFIED VIA EMAIL OF ALL POSSIBLE CHANGE ORDERS	
		ALL VISIBLE MILLWORK ELEVATED INCLUDING FINISHED END PANELS AND SOFFITS	
		PLAN AND VERTICAL SECTIONS CROSS CHECKED FOR ACCURACY	
		ALL MARKERS AND TAGS CHECKED AND VERIFIED TO BE CORRECT	
		ALL GRAIN DIRECTIONS CLEARLY INDICATED INCLUDING WOOD, METAL, AND PLAM FINISHES	
		APPLIANCES CHECKED AGAINST CUTS AND CUSTOM PANEL DRAWINGS CREATED AS NEEDED	
		DOOR HARDWARE SHOWN TO THE EXTENT POSSIBLE PER HARDWARE SCHEDULE AND CUTS	
		HARDWARE LOCATIONS DIMENSIONED OR REQUESTED FROM ENGINEERING MANAGER	
		ALL CABINET HARDWARE ACCURATELY LISTED INCLUDING FINISHES	
		ALL FINISHES ACCURATELY LISTED , INDICATED ON DRAWINGS, AND ASSIGNED TO SERIES	
		MATERIALS CHECKED AGAINST SCOPE TO VERIFY WHETHER PROVIDED BY MB	
		ALL NECESSARY FIELD DIMENSIONS INDICATED ON DRAWINGS	
		ALL FIELD DIMENSIONS APPLIED, ALL VIF DIMENSIONS REPLACED WTH FD	
		ENGINEERING MANAGER NOTIFIED OF MISSING FIELD DIMENSIONS	
		ALL +/- INDICATIONS REMOVED EXCEPT WHERE SCRIBE IS INVOLVED	
		ALL LOOSE JOINTS INDICATED CLEARLY	
		COMPONENT SIZES CHECKED AGAINST ELEVATOR SIZE TO ENSURE ACCESS	
		UNUSED GEOMETRY DELETED FROM DRAWING	
		UNUSED PAPERSPACE TABS DELETED FROM DRAWING	
		ALL RESOLVED QUESTIONS, CLOUDS, AND NOTES REMOVED FROM DRAWING	
		ENGINEERING MANAGER NOTIFIED BY EMAIL OF ANY NEW ISSUES WHICH REQUIRE ANSWERS	
		ITEMS READY FOR FABRICATION CLEARLY INDICATED OR ITEMS ON HOLD CLEARLY INDICATED	

USE ATTRIBUTE EDIT COMMAND ON AN ITEM TO EDIT USERNAME, DATE, AND COMMENTS

✓	DZALE	10/21/14	CHECKLIST ITEM	NO FOLLOW UP NEEDED
⬇	dzale	10/21/14	CHECKLIST ITEM	NEEDS FOLLOW UP
✓	NA	NA	CHECKLIST ITEM	NOT APPLICABLE

Date Drawn:	X	Dwg# X
Drawn by:	X	